

Name: _____

Student Manual

pGLO Transformation

Lesson 1 Introduction to Transformation

In this lab you will perform a procedure known as genetic transformation. Remember that a gene is a piece of DNA which provides the instructions for making (codes for) a protein. This protein gives an organism a particular trait. Genetic transformation literally means "change caused by genes," and involves the insertion of a gene into an organism in order to change the organism's trait. Genetic transformation is used in many areas of biotechnology. In agriculture, genes coding for traits such as frost, pest, or spoilage resistance can be genetically transformed into plants. In bioremediation, bacteria can be genetically transformed with genes enabling them to digest oil spills. In medicine, diseases caused by defective genes are beginning to be treated by gene therapy; that is, by genetically transforming a sick person's cells with healthy copies of the defective gene that causes the disease.

You will use a procedure to transform bacteria with a gene that codes for Green Fluorescent Protein (GFP). The real-life source of this gene is the bioluminescent jellyfish *Aequorea victoria*. Green Fluorescent Protein causes the jellyfish to fluoresce and glow in the dark. Following the transformation procedure, the bacteria express their newly acquired jellyfish gene and produce the fluorescent protein, which causes them to glow a brilliant green color under ultraviolet light.

In this activity, you will learn about the process of moving genes from one organism to another with the aid of a plasmid. In addition to one large chromosome, bacteria naturally contain one or more small circular pieces of DNA called plasmids. Plasmid DNA usually contains genes for one or more traits that may be beneficial to bacterial survival. In nature, bacteria can transfer plasmids back and forth allowing them to share these beneficial genes. This natural mechanism allows bacteria to adapt to new environments. The recent occurrence of bacterial resistance to antibiotics is due to the transmission of plasmids.

Bio-Rad's unique pGLO plasmid encodes the gene for GFP and a gene for resistance to the antibiotic ampicillin. pGLO also incorporates a special gene regulation system, which can be used to control expression of the fluorescent protein in transformed cells. The gene for GFP can be switched on in transformed cells by adding the sugar arabinose to the cells' nutrient medium. Selection for cells that have been transformed with pGLO DNA is accomplished by growth on ampicillin plates. Transformed cells will appear white (wild-type phenotype) on plates not containing arabinose, and fluorescent green under UV light when arabinose is included in the nutrient agar medium.

You will be provided with the tools and a protocol for performing genetic transformation.

Your task will be to:

1. Do the genetic transformation.
2. Determine the degree of success in your efforts to genetically alter an organism.

Consideration 3: The Genes

Genetic transformation involves the insertion of some new DNA into the *E. coli* cells. In addition to one large chromosome, bacteria often contain one or more small circular pieces of DNA called plasmids. Plasmid DNA usually contains genes for more than one trait. Scientists use a process called genetic engineering to insert genes coding for new traits into a plasmid. In this case, the pGLO plasmid has been genetically engineered to carry the GFP gene which codes for the green fluorescent protein, GFP, and a gene (*bla*) that codes for a protein that gives the bacteria resistance to an antibiotic. The genetically engineered plasmid can then be used to genetically transform bacteria to give them this new trait.

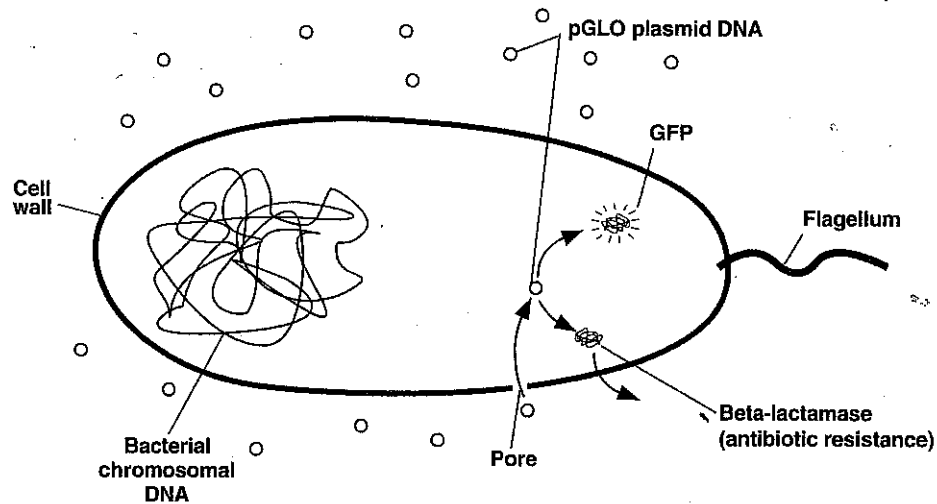

Consideration 4: The Act of Transformation

This transformation procedure involves three main steps. These steps are intended to introduce the plasmid DNA into the *E. coli* cells and provide an environment for the cells to express their newly acquired genes.

To move the pGLO plasmid DNA through the cell membrane you will:

1. Use a transformation solution containing CaCl_2 (calcium chloride).
2. Carry out a procedure referred to as **heat shock**.

For transformed cells to grow in the presence of ampicillin you must:

3. Provide them with nutrients and a short incubation period to begin expressing their newly acquired genes.

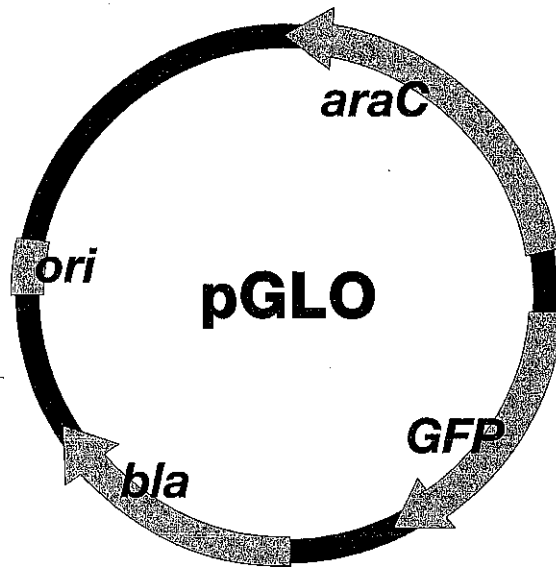

pGLO plasmid. Sequence and map are available at <http://explorer.bio-rad.com> under "Teaching Resources"

This is an excellent example of the central molecular framework of biology in action; that is, DNA→RNA→PROTEIN→TRAIT. When arabinose is absent from the growth media, the GFP gene remains turned off and the colonies appear white. A more detailed description and analysis of gene regulation and the function of the arabinose promoter can be found in Appendix A.

D

Appendix D Gene Regulation

Organisms regulate expression of their genes and ultimately the amounts and kinds of proteins present within their cells for a myriad of reasons, including developmental changes, cellular specialization, and adaptation to the environment. Gene regulation not only allows for adaptation to differing conditions, but also prevents wasteful overproduction of unneeded proteins which would put the organism at a competitive disadvantage. The genes involved in the transport and breakdown (catabolism) of food are good examples of highly regulated genes. For example, the sugar arabinose is both a source of energy and a source of carbon. *E. coli* bacteria produce three enzymes (proteins) needed to digest arabinose as a food source. The genes which code for these enzymes are not expressed when arabinose is absent, but they are expressed when arabinose is present in their environment. How is this so?

Regulation of the expression of proteins often occurs at the level of transcription from DNA into RNA. This regulation takes place at a very specific location on the DNA template, called a promoter, where RNA polymerase sits down on the DNA and begins transcription of the gene. In bacteria, groups of related genes are often clustered together and transcribed into RNA from one promoter. These clusters of genes controlled by a single promoter are called operons.

The three genes (*araB*, *araA* and *araD*) that code for three digestive enzymes involved in the breakdown of arabinose are clustered together in what is known as the arabinose operon.³ These three proteins are dependent on initiation of transcription from a single promoter, P_{BAD}. Transcription of these three genes requires the simultaneous presence of the DNA template (promoter and operon), RNA polymerase, a DNA binding protein called *araC* and arabinose. *araC* binds to the DNA at the binding site for the RNA polymerase (the beginning of the arabinose operon). When arabinose is present in the environment, bacteria take it up. Once inside, the arabinose interacts directly with *araC* which is bound to the DNA. The interaction causes *araC* to change its shape which in turn promotes (actually helps) the binding of RNA polymerase and the three genes *araB*, *A* and *D*, are transcribed. Three enzymes are produced, they break down arabinose, and eventually the arabinose runs out. In the absence of arabinose the *araC* returns to its original shape and transcription is shut off.

The DNA code of the pGLO plasmid has been engineered to incorporate aspects of the arabinose operon. Both the promoter (P_{BAD}) and the *araC* gene are present. However, the genes which code for arabinose catabolism, *araB*, *A* and *D*, have been replaced by the single gene which codes for GFP. Therefore, in the presence of arabinose, *araC* protein promotes the binding of RNA polymerase and GFP is produced. Cells fluoresce brilliant green as they produce more and more GFP. In the absence of arabinose, *araC* no longer facilitates the binding of RNA polymerase and the GFP gene is not transcribed. When GFP is not made, bacteria colonies will appear to have a wild-type (natural) phenotype—of white colonies with no fluorescence.

This is an excellent example of the central molecular framework of biology in action:

DNA→RNA→PROTEIN→TRAIT.

The Arabinose Operon

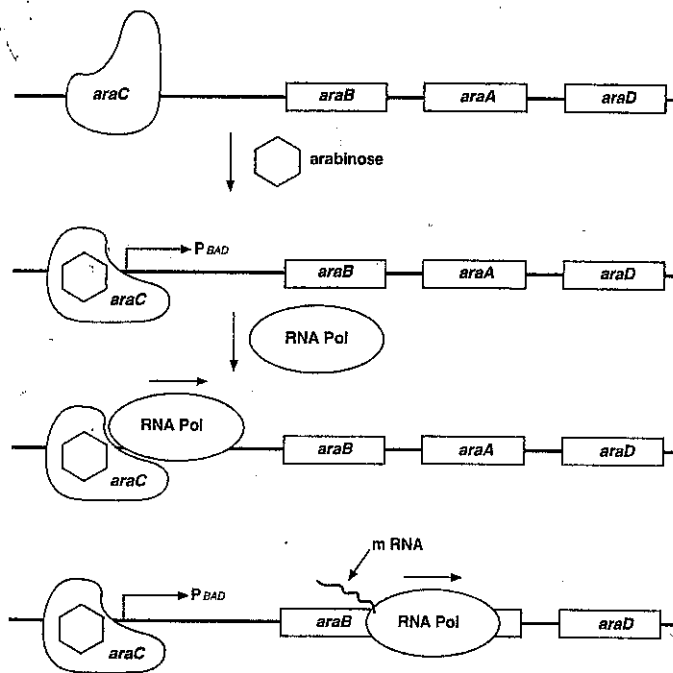

Expression of Green Fluorescent Protein

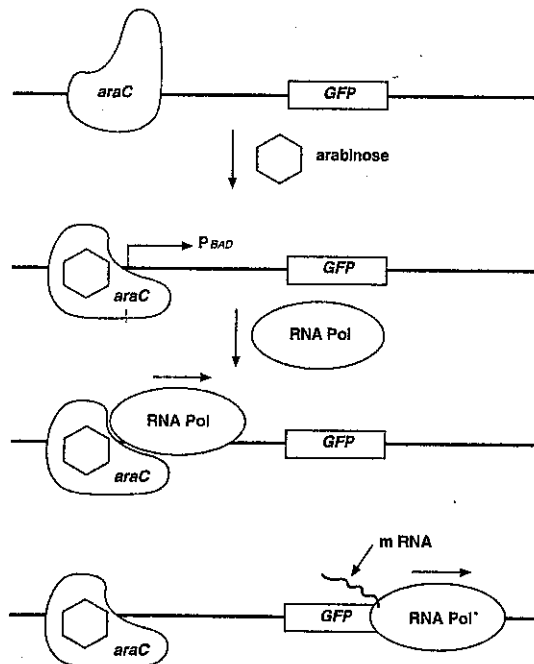

APPENDIX D